

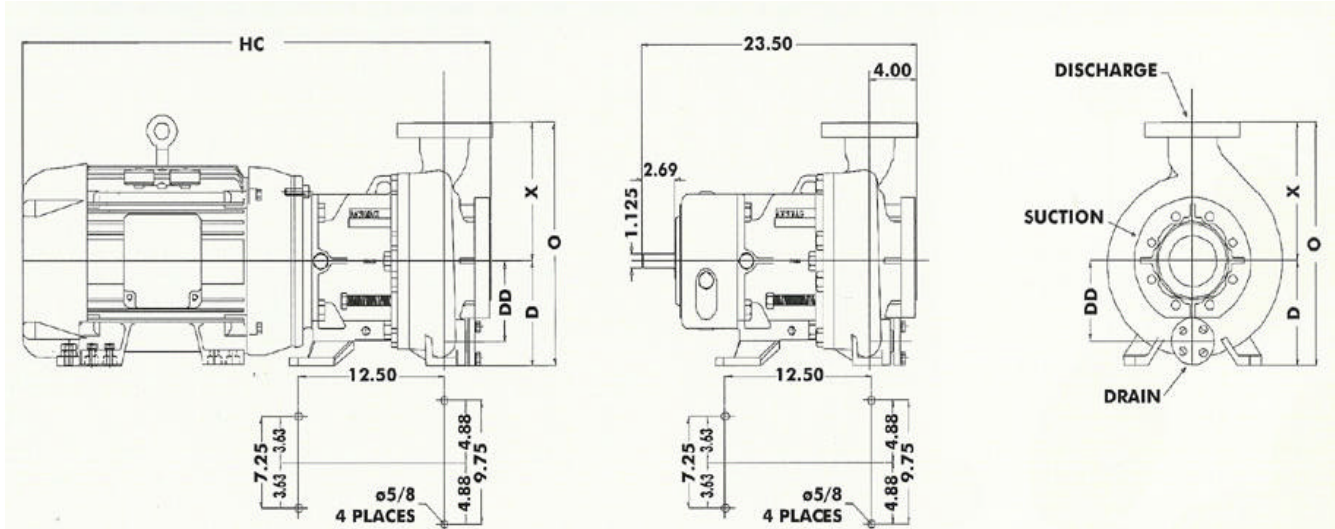

KF



DIMENSIONS ARE IN INCHES.

ANSI B73.1 NOMINAL	ANSIMAG MODEL	SUCTION FLANGE	DISCHARGE FLANGE	D	X	O	DD
A05	KF2110	2"	1"	8.25"	8.5"	16.75"	5.404"
A50	KF31510	3"	1.5"*	8.25"	8.5"	16.75"	5.68"
A60	KF3210	3"	2"*	8.25"	9.5"	17.75"	6.16"
A70	KF438	4"	3"	8.25"	11"	19.25"	6.3"
A70	KF4310	4"	3"	8.25"	11"	19.25"	6.38"
A80	KF6410	6"*	4"	10"	13.5"	23.5"	8.125"

* Flange has tapped bolt holes 3/4 - 10 NC

MOTOR FRAME NEMA	HC
182TC / 184TC	30
213TC / 215TC	34
254TC / 256TC	37
284TC / 286TC	42
324TC / 326TC	44
284TSC / 282TSC	41
324TSC / 326TSC	41
364TSC / 365TSC	42
405TSC	43

All flanges are raised face type with ANSI class 150 flanges as standard. ANSI class 300 flanges and ISO/DIN/JIS flanges are optional. Unmarked flanges have through holes according to ANSI #150/300 flanges dimensions of ASME/ANSI B73.

IEC MOTOR DIMENSIONS AVAILABLE UPON REQUEST.

DIMENSIONAL DRAWINGS ARE FOR REFERENCE ONLY, NOT FOR CONSTRUCTION.